



**S.S. Automobiles**  
An ISO 9001:2015 Company



Email: [sshardeep@hotmail.com](mailto:sshardeep@hotmail.com)  
[ssmumbai@hotmail.com](mailto:ssmumbai@hotmail.com)  
Web: [www.ssautomobile.in](http://www.ssautomobile.in)

## Trailer Under Carriage Systems

Mechanical Suspension

Landing Gear

Trailer Axle

King Pin



S.S. Automobiles is one of the fastest growing Automobile Trailer Products and Components Supplier Company based in Mumbai, India.

SS Group was founded in 1965 by the efforts of Mr. Pritam Singh, the company's beginnings were quite modest as compared to its present. Since then, under the guidance of Mr. Dilprit Singh (Managing Director) & Mr. Hardeep Singh (Director), we have diversified into other areas of automobile components by starting up S. S. Automobiles mainly to deal with supply of Trailer products and its Components.

We are active members of renowned organizations like EEPC (Engineering Export Promotion Council) and BMMA (Bombay Motor Merchants' Association).

The industry's best known company from Mumbai, India, S.S. Automobiles has a broad line up of its main Trailer Products and its Components such as, Trailer Axles, Mechanical Suspension, Kingpins, Landing Gears, Brake Drum, Wheel Hub, Wheel Bearing, Wheel Bolt, Hub Seal and Hub Cover with improved performance, and a premium high performance tuning class to satisfy the specific needs of its customers. We regard customer satisfaction as the utmost value so that the customers can use the products with peace of mind for a long time.

Our success is attributed to our customer loyalty and satisfaction. Constantly developing new products and providing high standard, intricate components at competitive prices to our clients is the main objective. Although much has changed since 1965, our enthusiasm for providing excellent service hasn't. After all, it's been the greatest reason for our success.

### Values

- Total commitment to quality, durability and reliability.
- Going the extra mile with our clients to establish a successful and long-term business relationship.
- Constantly seeking ways and means to provide higher level of customer satisfaction.
- Extensive market research to understand and meet with the growing demands of the ever-changing logistic industry.
- Continuously upgrade quality standards in line with the trends for the next millennium thereby benefiting the customer.

### Special Services

- We undertake turnkey projects as per customers requirements.
- We can develop your product against samples for your specific requirements.
- We can also partner with you in developing new products.

### Vow to our Customers

At the end of the day, our only assets are our clients and our reputation. We need to exceed each and every expectation that our client has - this means we also have to anticipate and manage future expectations. This also means never over-committing.

### Conclusion

With a continuous endeavour to excel through innovative and unique automobile solutions, S.S. Automobiles has earned the confidence and respect of the Indian logistic industry.



**S.S. Automobiles**

**Head Office :** Survey No. 190, Hissa No. 1-4, Ghodbunder Village Road, Post Mira, Thane Dist. 401104. Off. Western Express Highway, Maharashtra, India  
Tel.: +91 22 28455111 / +91 22 28458378 / +91 22 28458343  
Fax: +91 22 28454501 • Tel.: +91 9820064848



## TRAILER AXLES

Fully Dressed Trailer Axles (Single Beam)



### MORE DISTANCELESS MAINTENANCE

Premium quality range of Trailer Axles produced to OEM specifications covering all major Indian Trailer applications. Manufactured from premium grade material and fully machined to compounds.

- Induction hardened spindles for the rough Indian terrain
- Housings with optimum thickness to withstand abuse and neglect
- Anti-corrosive paint coating for longer life
- Wide range of compatible brake parts to suit each and every trailer application
- Permanently marked with the brand name, logo and part number to ensure genuine parts and allow instant part identification both on and off the trailer.
- Market competitive prices with unmatched performance and durability

## MECHANICAL SUSPENSIONS

Indian/Chinese type suspension 10,12 & 14 tons

### TECHNICAL PARAMETERS



#### TANDEM/DOUBLE SUSPENSION WITH 8/9-LEAF SPRING

ITEM	A1 (mm)	A1* (mm)	A2 (mm)	A2* (mm)	H (mm)
6.2101/12F	424	384	415	375	142
6.2102/12F	449	409	440	400	167
6.2103/12F	474	434	465	425	192
6.2104/12F	499	459	490	450	217
6.2105/12F	524	484	515	475	242

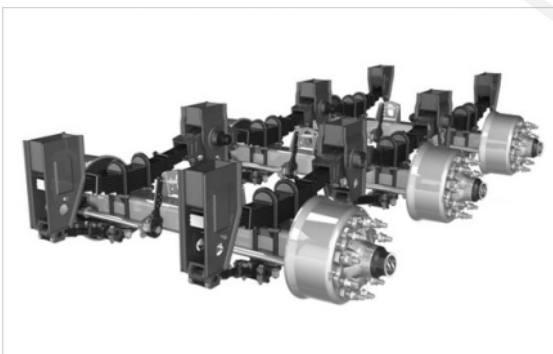

#### TRIPLE/TRIDEM SUSPENSION WITH 8/9-LEAF SPRING

ITEM	A1 (mm)	A1* (mm)	A2 (mm)	A2* (mm)	A3 (mm)	A3* (mm)	H (mm)
6.3101/12F	433	393	424	384	415	375	142
6.3102/12F	458	418	449	409	440	400	167
6.3103/12F	483	443	474	434	465	425	192
6.3104/12F	508	468	499	459	490	450	217
6.3105/12F	533	493	524	484	515	475	242

#### NOTE:

1. 90mmx16mmx8/9 leaf suggested leaf spring
2. Amounting height for unloading status
3. A\* mounting height in rated loading status

#### PRODUCT FEATURES

- High-strength material with strong carrying capacity, remarkable wear resistance property and performance stability and long service life.
- Wheel Track adjustable easily and accurately, which protect the tires from abnormal wear.
- Easy for fitting and swift maintenance.
- Passed strict bench testing and road testing.
- Lightweight design.



**KING PIN SERIES**  
King Pins 2 & 3.5 inches



**PRODUCT FEATURES**

- Manufactured from high tensile drop forgings and heat-treated.
- Available in bolt-on series and welded series.
- Complies with German and American standard

**TECHNICAL PARAMETERS**

**King Pins 2 & 3.5 inches**

Description	Model No.	Spec	Slide Plate Thickness (A)
<b>H50 (2" Welding type)</b>			
2" Weldable King Pin	H50-08	2" -50mm	8mm
2" Weldable King Pin	H50-10	2" -50mm	10mm
2" Weldable King Pin	H50-12	2" -50mm	12mm
<b>Z50 (2" Assembling type)</b>			
2" Bolton King Pin	Z50-08	2" -50mm	8mm
2" Bolton King Pin	Z50-10	2" -50mm	10mm
2" Bolton King Pin	Z50-12	2" -50mm	12mm
<b>Z90A (3.5" Assembling type)</b>			
3.5" A Bolton King Pin	Z90A-08	3.5" -90mm	8mm
3.5" A Bolton King Pin	Z90A-10	3.5" -90mm	10mm
3.5" A Bolton King Pin	Z90A-12	3.5" -90mm	12mm
3.5" A Bolton King Pin	Z90A-14	3.5" -90mm	14mm
3.5" A Bolton King Pin	Z90A-16	3.5" -90mm	16mm
<b>Z90C (3.5" Assembling type)</b>			
3.5" C Bolton King Pin	Z90C-08	3.5" -90mm	8mm
3.5" C Bolton King Pin	Z90C-10	3.5" -90mm	10mm
3.5" C Bolton King Pin	Z90C-12	3.5" -90mm	12mm
3.5" C Bolton King Pin	Z90C-14	3.5" -90mm	14mm
3.5" C Bolton King Pin	Z90C-16	3.5" -90mm	16mm

**LANDING GEARS**

Landing gears 17.5 & 18.5 Bolt size



**PRODUCT FEATURES**

- Numbers of innovative design make the product easy to use and convenient to maintain.
- Comply with Indian Safety Regulation For Commercial Vehicles.
- Light weight design maintaining the reliability feature improves the carrying capacity of the vehicle effectively.
- High strength material with unparalleled carrying capacity.
- Brand new gear ratio, easy and swift for operation.
- Feed screw nut with grease storage lengthens the service cycle greatly.

**TECHNICAL PARAMETERS**

Types	Part No.	Lift	Height
80001T	T	430	794
80002T	T	480	844
<b>Standard Specification</b>			
Capacity	28.000 kg/pair		
Static Load	80,000 kg/pair		
Weight	98 kg		
<b>Crank Force</b>			
Low Gear	0.42mm Per Trun (mm/r) of handle		
High Gear	3.5mm Per Trun (mm/r) of handle		

Types	Part No.	Lift	Height
80001T	T	430	830
80002T	T	480	880
80001S	S	430	870
80002S	S	480	920
<b>Standard Specification</b>			
Capacity	28.000 kg/pair		
Static Load	80,000 kg/pair		
Weight	102 kg		
<b>Crank Force</b>			
Low Gear	0.9mm Per Trun (mm/r) of handle		
High Gear	9mm Per Trun (mm/r) of handle		





## Components for Axle



## Components for Suspensions

